

# COMBi-OP ORDER PICKER

The Combi-OP is a safe robust work platform for efficient processing of multiple orders and long loads.

# COMBiLiFT

LIFTING INNOVATION

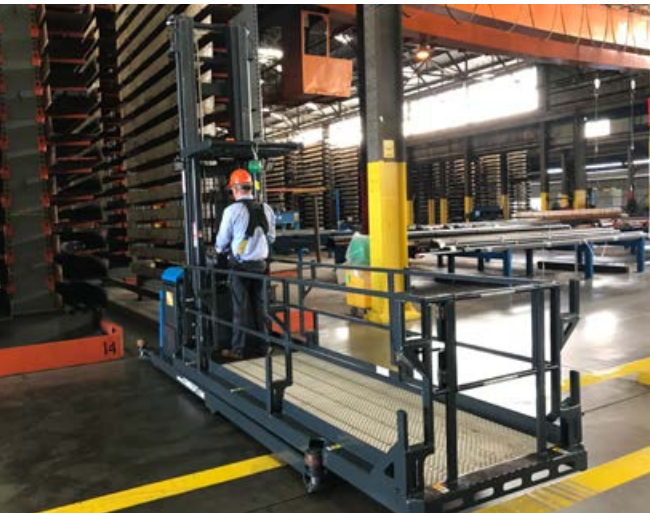

# COMBI-OP ORDER PICKER

**SIDE VIEW**

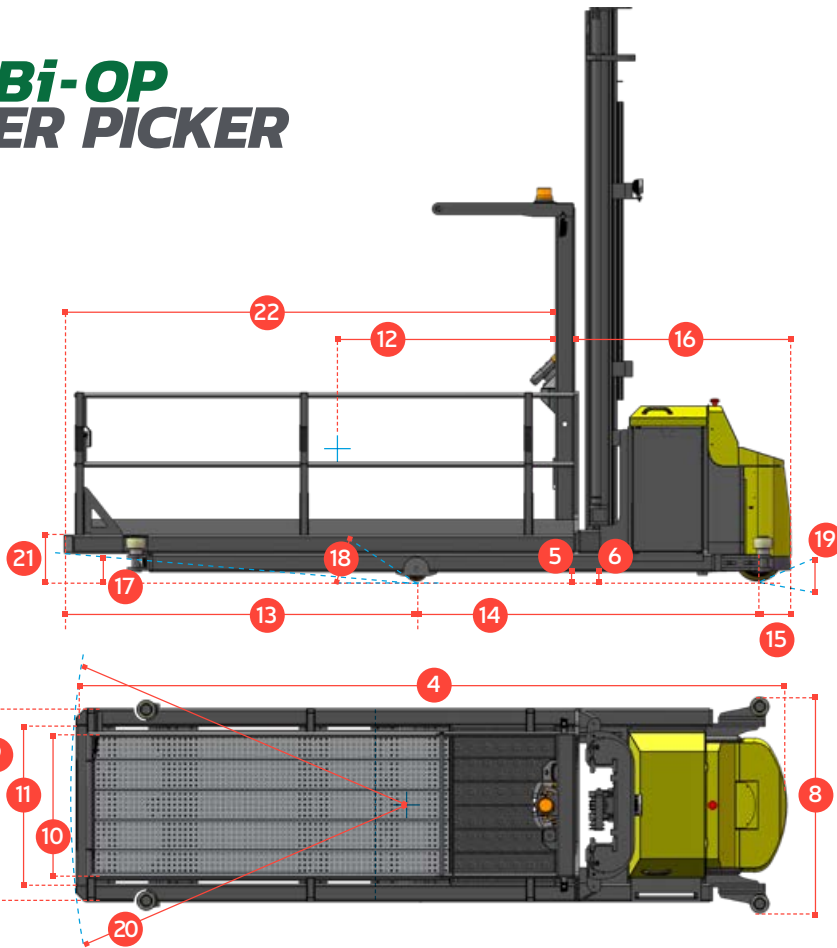

**PLAN VIEW**

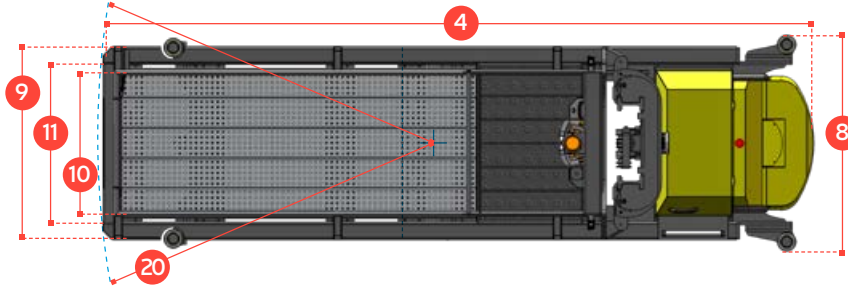

**FRONT VIEW**

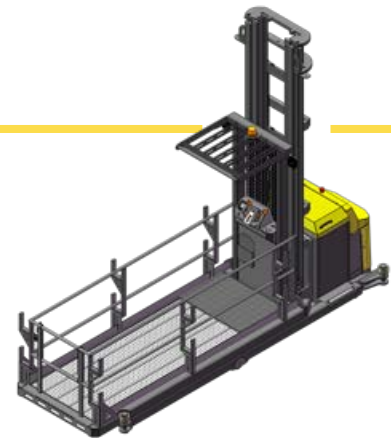
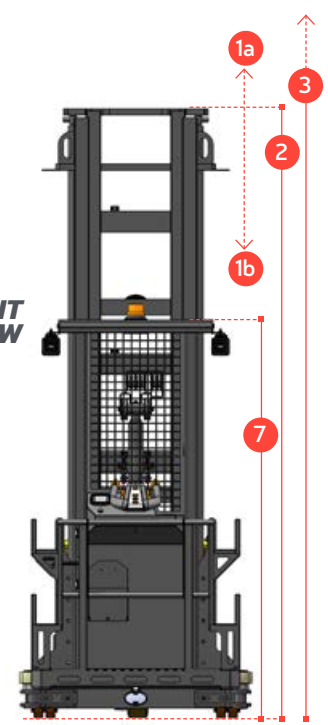

REF.	DESCRIPTION	STANDARD
1a	Standard Lift Height	236"
1b	Free Lift Height	50"
2	Height Mast Closed	148"
3	Mast Raised	334"
4	Overall Length	186"
5	Ground Clearance Under Mast	2¼"
6	Ground Clearance to Centre of Wheelbase	2¼"
7	Height Over Guard	98"
8	Width Across Rollers	56½"
9	Platform Outer Width	50½"
10	Platform Inner Width	35½"
11	Track Front	44"
12	Load Centre Distance	72"
13	Overhang Front	90"
14	Wheelbase	87"
15	Overhang Back	8½"
16	Length from Face of Platform	60"
17	Approach Angle	1½°
18	Ramp Angle	6°
19	Departure Angle	20°
20	Turning Radius	110"
21	Platform Height	12"
22	Platform Length	125½"
A	Capacity	1000 lbs
B	Unladen Weight (No Battery)	8900 lbs
C	Maximum Ground Speed	6 mph
D	Gradeability	2%
E	AC Rear Drive	5½ HP
F	AC Pump Motor	7 HP
G	Battery	48 V x 700 Ah
H	Vulkollan Front Tyre x 4	OD 6" / Width 2"
I	Vulkollan Rear Tyre	OD 12" / Width 5"
J	Standard Colour	Yellow & Grey

## Features Include:

- Standing Operator Over-Head Guard
- Multi-function Steering/Function Console
- Platform End Entry/Exit Gate
- Dual Speed Control
- AC Electric Steering
- Operators Display
- AC Motor Technology
- Guide Rollers
- LED Work-lights

## Distributed by:

COMBILIFT HAS A POLICY OF CONTINUOUS PRODUCT DEVELOPMENT AND RESERVES THE RIGHT TO ALTER SPECIFICATIONS WITHOUT PRIOR NOTICE. SPECIFICATIONS AND/OR DIMENSIONS MAY VARY FROM THOSE ILLUSTRATED IN SOME COUNTRIES.

303 CONCORD STREET,  
GREENSBORO,  
NORTH CAROLINA 27406

TOLL FREE: 1-877 COMBI 56  
TEL: 336-378-8884  
INFO@COMBILIFT.COM

**combilift.com**

# COMBI-OP ORDER PICKER

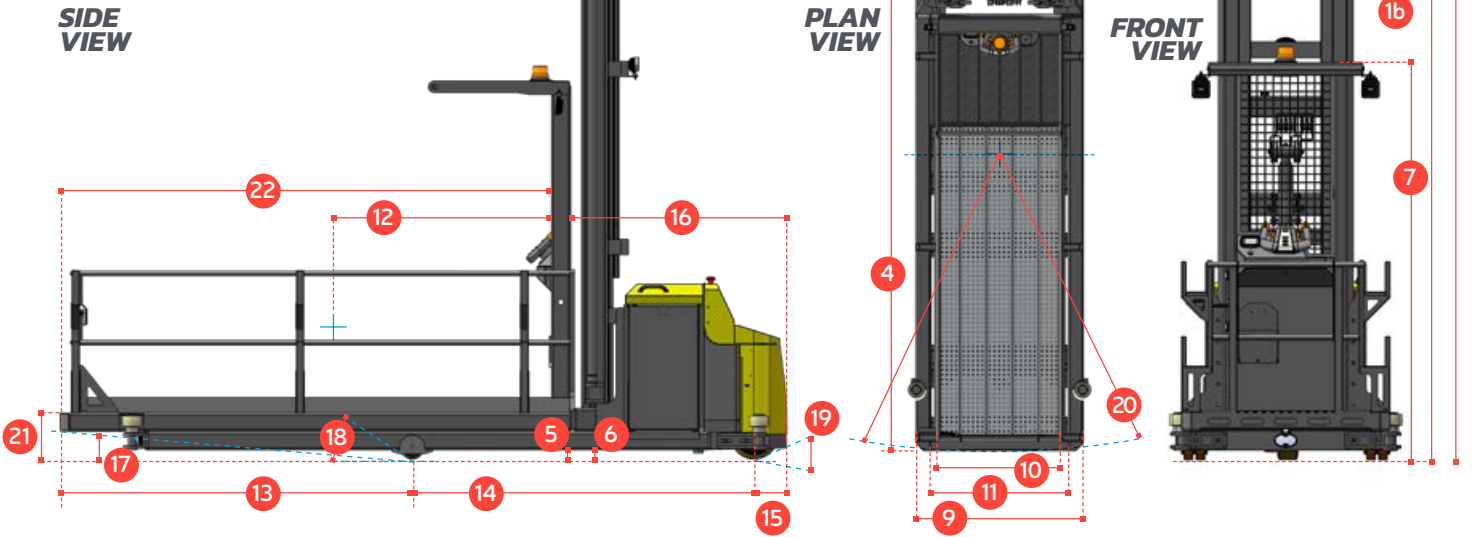

REF.	DESCRIPTION	Standard
1a	Standard Lift Height	236"
1b	Free Lift Height	50"
2	Height Mast Closed	148"
3	Mast Raised	334"
4	Overall Length	186"
5	Ground Clearance Under Mast	2¼"
6	Ground Clearance to Centre of Wheelbase	2¼"
7	Height Over Guard	98"
8	Width Across Rollers	56½"
9	Platform Outer Width	50½"
10	Platform Inner Width	35½"
11	Track Front	44"
12	Load Centre Distance	52"
13	Overhang Front	90"
14	Wheelbase	87"
15	Overhang Back	8½"
16	Length from Face of Platform	60"
17	Approach Angle	1½°
18	Ramp Angle	6°
19	Departure Angle	20°
20	Turning Radius	110"
21	Platform Height	12"
22	Platform Length	125½"
A	Capacity	1000 lbs
B	Unladen Weight (No Battery)	8900 lbs
C	Maximum Ground Speed	6 mph
D	Gradeability	2%
E	AC Rear Drive	5½ HP
F	AC Pump Motor	7 HP
G	Battery	48 V x 700 Ah
H	Vulkollan Front Tyre x 4	OD 6" / Width 2"
I	Vulkollan Rear Tyre	OD 12" / Width 5"
J	Standard Colour	Yellow & Grey

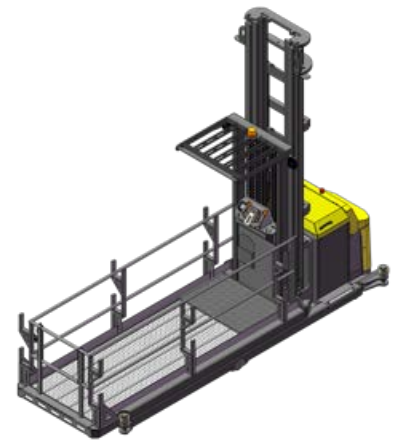

## Features Include:

- Standing Operator Over-Head Guard
- Multi-function Steering/Function Console
- Platform End Entry/Exit Gate
- Dual Speed Control
- AC Electric Steering
- Operators Display
- AC Motor Technology
- Guide Rollers
- LED Work-lights

## Distributed by:

COMBILIFT HAS A POLICY OF CONTINUOUS PRODUCT DEVELOPMENT AND RESERVES THE RIGHT TO ALTER SPECIFICATIONS WITHOUT PRIOR NOTICE. SPECIFICATIONS AND/OR DIMENSIONS MAY VARY FROM THOSE ILLUSTRATED IN SOME COUNTRIES.

303 CONCORD STREET,  
GREENSBORO,  
NORTH CAROLINA 27406

TOLL FREE: 1-877 COMBI 56  
TEL: 336-378-8884  
INFO@COMBILIFT.COM

[combilift.com](http://combilift.com)